



Instructions for Use for the Start series

Contents

Page

1	General Information	35
	<i>1.1 Preface</i>	<i>35</i>
	<i>1.2 Intended Use</i>	<i>35</i>
	<i>1.3 Field of Application</i>	<i>35</i>
	<i>1.4 CE conformity</i>	<i>36</i>
	<i>1.5 Liability</i>	<i>36</i>
2	Safety Instructions	36
	<i>2.1 Symbol Legend</i>	<i>36</i>
	<i>2.2 General Safety Instructions</i>	<i>37</i>
3	Delivery / Preparing the Wheelchair for Use	40
4	Folding – Transport	41
5	Accessories	42
	<i>5.1 Anti-tipper.....</i>	<i>42</i>
	<i>5.2 Transport wheels.....</i>	<i>42</i>
	<i>5.3 Crutch holder with hook and loop strap.....</i>	<i>43</i>
	<i>5.4 Side panels (flip-up and removable).....</i>	<i>43</i>
	<i>5.5 Plug-on wheel lock lever extension</i>	<i>43</i>
	<i>5.6 Drum brakes</i>	<i>43</i>
	<i>5.7 Wheel lock for one-handed operation</i>	<i>44</i>
	<i>5.8 Tray.....</i>	<i>44</i>
	<i>5.9 Lap belt</i>	<i>44</i>
	<i>5.10 Elevating footrest</i>	<i>44</i>
	<i>5.11 Push handles, height adjustable / removable</i>	<i>45</i>
	<i>5.12 Wheelbase extension</i>	<i>45</i>
	<i>5.13 Back upholstery, adaptable</i>	<i>45</i>
	<i>5.14 Folding back</i>	<i>45</i>
	<i>5.15 Spoke protectors.....</i>	<i>45</i>
	<i>5.16 Amputation legrest.....</i>	<i>46</i>
	<i>5.17 Infusion stand.....</i>	<i>46</i>
	<i>5.18 The Back</i>	<i>46</i>
	<i>5.19 The Seat.....</i>	<i>46</i>

6	Adjustment / Assembly Instructions	47
	<i>6.1 Adjusting seat height and seat inclination.....</i>	<i>47</i>
	<i>6.2 Changing the wheelbase.....</i>	<i>48</i>
	<i>6.3 Caster wheels.....</i>	<i>49</i>
	<i>6.4 Wheel lock.....</i>	<i>50</i>
	<i>6.5 Adjusting the brake force for rear wheel with drum brake.....</i>	<i>51</i>
	<i>6.6 Adjusting the angle of the footplate</i>	<i>51</i>
	<i>6.7 Adjusting the height of the footrest.....</i>	<i>52</i>
	<i>6.8 Adjusting the angle of the elevating footrest.....</i>	<i>52</i>
	<i>6.9 Adjusting the height of the armrest for desk side panel.....</i>	<i>53</i>
	<i>6.10 Adjusting the seat depth</i>	<i>53</i>
	<i>6.11 Adjusting the back height.....</i>	<i>54</i>
	<i>6.12 Seat upholstery</i>	<i>54</i>
	<i>6.13 Adapting the back upholstery</i>	<i>55</i>
	<i>6.14 Setting rear wheel tracking (M5).....</i>	<i>56</i>
7	Maintenance, Cleaning and Care	57
8	Changing Tires	58
9	Technical Data.....	60
10	Information on Re-Use	67

1 General Information

1.1 Preface

Congratulations on choosing a lightweight wheelchair from the Start series, a high-quality product that offers versatile applications for everyday use at home and outdoors. Before using your wheelchair, it is essential to read the sections “Delivery / Preparing the Wheelchair for Use” and “Safety Instructions” .

The section “Accessories” presents additional components of the Start which can expand its field of application and improve its comfort. The section “Adjustment / Assembly Instructions” provides an overview of the possibilities to customize the wheelchair to your personal needs and preferences. The model as described in these Instructions for Use is subject to technical changes without notice.

1.2 Intended Use

The lightweight wheelchairs of the Start series are designed solely for people who are unable to walk or who have a walking impediment. The wheelchairs can be moved either by the patients themselves or by another person.

The Otto Bock warranty applies only when the product is used according to the specified conditions and for the intended purposes, following all manufacturer’s recommendations.

1.3 Field of Application

The versatility of the Start series wheelchairs and their modular design make them suitable for patients who have walking impediments or walking disabilities due to:

- Paralysis
- Loss of limbs (lower limb amputation)
- Defective or deformed limbs
- Joint contractures or defects
- Diseases such as cardiac or circulatory insufficiency, balance disorders or cachexia as well as for geriatric patients who still have usable residual strength in the upper limbs.

Fitting considerations:

- Body height and body weight (max. load 125 kg (for M4 XXL: 160 kg, for M6 Junior: 90 kg)
- Physical and psychological limitations
- Age of the patient
- Home and living conditions
- Environment

1.4 CE conformity

This product meets the requirements of the 93/42/EWG guidelines for medical products. This product has been classified as a class I product according to the classification criteria outlined in appendix IX of the guidelines. The declaration of conformity was therefore created by Otto Bock with sole responsibility according to appendix VII of the guidelines.

1.5 Liability

The manufacturer's warranty applies only if the product has been used under the conditions and for the purposes described. The manufacturer recommends that the product be used and maintained according to the instructions for use.

The manufacturer is not responsible for damages caused by components and spare parts not approved by the manufacturer. Repairs must be carried out exclusively by authorized dealers or by the manufacturer.

2 Safety Instructions

2.1. Symbol Legend



DANGER!

Warning messages regarding possible risks of accident or injury.



CAUTION!

Warning messages regarding possible technical damages.



INFORMATION!

Information for operating the product.



INFORMATION!

Information for service staff.



ATTENTION!

Read the Instructions for Use first!

2.2 General Safety Instructions



DANGER!

All brakes acting on the tires do not serve as service brake but are only designed as parking brake (wheel lock).



DANGER!

To avoid tipping and dangerous situations, familiarize yourself with your new wheelchair by practicing on level ground first.



DANGER!

Do not use the footplates as a step stool when getting into or out of your wheelchair. These should be flipped and swung out of the way first, if possible.



DANGER!

Depending on the diameter and setting of the casters as well as the setting of the wheelchair's center of gravity, the casters may flutter when driving at higher speeds. This can lead to blocking of the casters and cause the wheelchair to tip over. Therefore, ensure that the casters are properly adjusted (see section "Adjustment / Assembly Instructions"). Especially on slopes, do not drive without braking and reduce your speed.



DANGER!

Get to know how the wheelchair reacts when the center of gravity shifts; for example on slopes or inclines or when clearing obstacles such as steps and curbs. This should be done only with assistance from another person. Using the anti-tipper is strongly recommended for untrained wheelchair users.



DANGER!

The anti-tipper is designed to prevent the wheelchair from tipping backwards. Under no condition should the anti-tipper be used as transport wheels, e.g. when wanting to push the wheelchair while the rear wheels are removed.



DANGER!

Extreme settings (e.g. rear wheels mounted in the foremost position, M4 / M5) combined with disadvantageous body postures can tip the wheelchair even when on level ground.



DANGER!

When ascending slopes, lean your upper body far forward.



DANGER!

When reaching for objects in front, to the side or behind the wheelchair, do not lean out of the wheelchair too far as this will shift the center of gravity and cause the chair to tilt or tip over.



DANGER!

Use your wheelchair properly. For instance, do not "jump" the chair down from higher surfaces and do not drive against obstacles such as steps and curbs without braking.



DANGER!

Do not ascend or descend stairs without the assistance of attendants. Make use of ramps or elevators whenever available. If wheelchair-friendly access is missing, two attendants must carry the wheelchair over the obstacle.

If only one attendant is available, he or she must adjust the anti-tipper (if mounted) such that it does not come in the way of the steps during transport. Failure to observe this precaution can lead to severe falls. Afterwards, the anti-tipper should be swung back to its operational position.



DANGER!

Advise attendants to lift your wheelchair only by parts that are firmly attached (e.g. not at the footrest or the flip-up side panels).



DANGER!

If your wheelchair is equipped with height-adjustable push handles, ensure that the clamping levers are firmly tightened.



DANGER!

When using lifting platforms, ensure that the anti-tipper is outside the danger-area.



DANGER!

Engage the wheel locks to prevent the wheelchair from moving on uneven ground or during transfers (e.g. into a car).



DANGER!

Before starting your wheelchair, check the tires for proper inflation levels. The required air pressure is printed on the side of the tire. For rear wheels, it should be at least 3.5 bar (350 kPa). The wheel locks are only effective with sufficient air pressure and proper adjustment (approx. 4 mm distance, subject to technical changes).



DANGER!

For transfemoral amputees, the rear wheels must be shifted backwards.



ATTENTION!

If your seat and back upholstery become worn out or damaged, replace it promptly. With a new seat upholstery you will automatically receive new lamellar plugs for the seat tube which you should replace for the previously used, old lamellar plugs.



DANGER!

Use caution near flammables or fire, especially lit cigarettes. The seat and backrest upholstery might catch fire.



DANGER!

To avoid hand injuries, do not grasp between the rear wheel and the wheel lock when driving your wheelchair.



DANGER!

The maximum load for modules **M1**, **M2**, **M3** and **M5** is **125 kg**.
The maximum load for module **M4** is **160 kg** and for module **M6** **90 kg**.



DANGER!

Using your Otto Bock product as a seat for transportation in motor vehicles for disabled passengers

Whenever possible, users should be transferred to the seats installed in the motor vehicle for disabled passengers. The corresponding restraint systems should also be used. Only this can ensure optimal protection of the passengers in case of an accident.

The modules M1, M2, M3, M5 and M6 are permissible for transporting passengers in motor vehicles when using Otto Bock safety components and when using appropriate restraint systems.

For more information, please refer to our instructions for use manual "Using your Wheelchair/ Mobility Base with Seating Shell or Buggy/Stroller as a Seat for Transportation in Motor Vehicles", order no. 646D158.



DANGER!

Always make sure that the quick-release axles are correctly set on the rear wheel. The rear wheel must not be removable without the button of the quick-release axle being depressed.



DANGER!

Slowing down from high speeds or when descending longer slopes tends to heat up the hands and fingers, especially if using aluminum push rings.



DANGER!

When using your wheelchair outdoors, wear leather gloves. Gloves provide you with a better grip and protect your fingers from dirt and hot metal.



DANGER!

The effectiveness of the wheel lock and the overall driving quality are dependent on adequate air pressure.

Properly inflated rear wheel tires and equal air pressure in both tires considerably improve the maneuverability of your wheelchair.



DANGER!

Ensure that the tires have sufficient tread depth.

When using your wheelchair in public traffic, you are subjected to public traffic regulations.



DANGER!

Ensure you are visible in the dark. If possible, wear light-colored clothes or clothing with reflectors, and ensure that the reflectors installed at the side and the rear of the wheelchair are clearly visible. We also recommend installing lights.

3 Delivery / Preparing the Wheelchair for Use



DANGER!

Risk of injury: Do not hold on to other moveable parts than the ones described.

Wheelchairs of the Start series are generally delivered completely assembled and folded.

Three simple steps prepare it for use:

- 1) When folding or unfolding the wheelchair, hold it only at the indicated positions (Fig. 1, Fig. 3).
- 2) While standing next to the wheelchair, tip it slightly toward you and press on the edge of the seat upholstery closest to you. The wheelchair will unfold up to its entire seat width (Fig. 1).
- 3) Push the footplates down (Fig. 2).



The overhang of the back upholstery attaches easily to the seat upholstery with a hook-and-loop closure. We recommend keeping the overhang attached at all times.

4 Folding – Transport



INFORMATION!

Flip up the footplates. Grab the seat upholstery at the front and the back in the middle and pull it upwards. The wheelchair then folds into itself (Fig. 3).



INFORMATION!

Once the wheelchair is folded, secure the strap of the folding fixture with the snap fastener. This will prevent the wheelchair from unfolding unexpectedly (Fig. 3A). For more manageable transportation, e.g. in cars, the footrests can be swung inwards or outwards or be entirely removed.



INFORMATION!

To move or remove the footrest, pull the lock release assist (Fig. 4) to the rear. The footrest with footplate can then be swung inwards or outwards or be removed by pulling it upward.



INFORMATION!

During reassembly, ensure that the footrest locking device has engaged. Transportation is greatly facilitated by the removable quick-release axles on the rear wheels (included in the standard version) (Fig. 5).





INFORMATION!

Slide four fingers between the spokes near the hub of the rear wheel. Then press the button of the quick-release axle with your thumb. You can then easily pull off the rear wheel.

Follow the corresponding procedure when remounting.



INFORMATION!

When remounting, be sure the quick-release axle securely locks into the quick-release axle housing.

The rear wheel must not be removable when the button is not being pressed!

5 Accessories

The wheelchair is designed as a modular assembly system. This means that certain accessories can be adapted to your wheelchair. In the following, we will present you a selection of our variants and accessories which improve the use and comfort of your wheelchair.

5.1. Anti-tipper (Fig. 6)

Prevents the wheelchair from tipping too far backward. Strongly recommended for untrained wheelchair users as well as when extreme adjustments have been made to the rear wheel.

5.2. Transport wheels (Fig. 7)

With the rear wheels removed, the wheelchair can be used as a rolling base. This allows maneuvering through narrow passage ways (such as bathroom doorways or airplane aisles).



INFORMATION!

Please note that once the rear wheels are removed, the wheel locks can no longer be activated!



5.3. Crutch holder with hook and loop strap (Fig. 8)

5.4. Side panels (flip-up and removable) (Fig. 9)

Available in several models, also with height-adjustable armrests; side panels can be flipped up or removed for getting into or out of the wheelchair. To flip up the side panel, manipulate the release lever behind the side panel tube.



5.5. Plug-on wheel lock lever extension (Fig. 10)

Facilitates use of the wheel lock.

5.6. Drum brakes (Fig. 11)

Allow the attendant to comfortably and safely brake the wheelchair. The rear wheels remain removable via the quick-release axle system.



5.7. Wheel lock for one-handed operation (Fig. 12)



INFORMATION!

Please note that the wheel lock lever extension must always be attached when releasing or engaging the wheel lock.

Recommended especially for hemiplegics. It can be activated either on the right or left side and ensures the safe locking of both rear wheels with a pull-wire system.

5.8. Tray (Fig. 13)

Serves as a supporting surface during meals, when working or when playing. The clear material allows visibility of the legs and correction of the sitting posture.



5.9. Lap belt (Fig. 14)

Prevents the wheelchair user from falling out of the wheelchair.

5.10 Elevating footrest (Fig. 15)

Allows positioning of the leg at different angles. Upon manipulation of the release lever which is integrated into the legrest bearing the footrest angle can be adjusted in small increments.



5.11 Push handles, height-adjustable (Fig. 16)

Can be adjusted vertically to a more comfortable height for the attendant.

5.12 Wheelbase long (Fig. 17)

Makes the wheelchair particularly stable against tipping, increases the turning range.



INFORMATION!

For transfemoral amputees the long wheelbase setting is indispensable.



5.13 Back upholstery, adaptable (Fig. 18)

5.14 Folding back (Fig. 19)

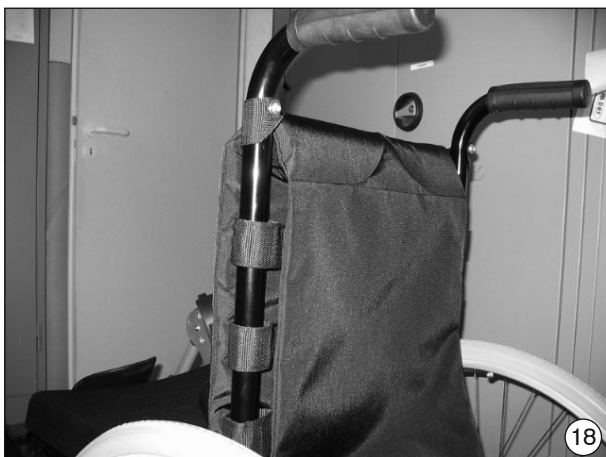

5.15 Spoke protectors

Protect the fingers from getting caught in the wheel spokes. Also improve the appearance of the wheelchair.

5.16 Amputation legrest (Fig. 20)

5.17 Infusion stand (Fig. 21)



5.18 The Back (Fig. 22)

Firm back to support positioning (see 647H491 Instructions for Use).

5.19 The Seat (Fig. 23)

Seat base with variable setting possibilities to improve positioning (see 647H450 Instructions for Use).

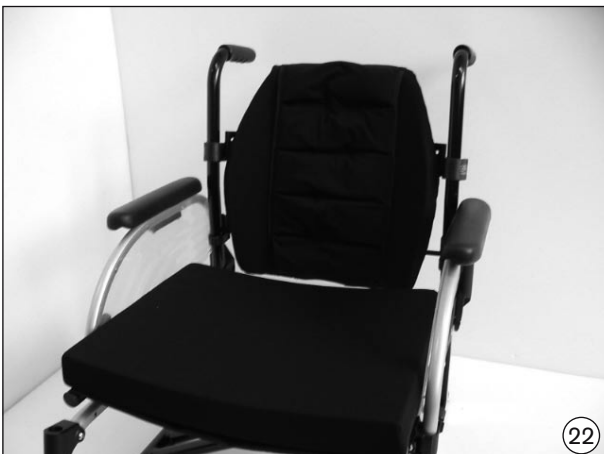

6 Adjustment / Assembly Instructions

All wheelchair users have expectations regarding wheelchair type, accessories, seating and handling.

Your Start wheelchair has many options by which it can be customized to your needs and preferences. We recommend consulting with your dealer or therapist to determine which wheelchair settings will work best for you.



INFORMATION!

The following tools are required for repair and maintenance:

- Allen wrenches, sizes 4 and 5 mm
- Torx Allen wrenches, sizes x 30
- Open-end wrenches, sizes 19 and 24 mm
- Socket wrenches, sizes 10 and 19 mm
- Phillips head screwdriver
- Tire levers
- Torque wrench

6.1. Adjusting seat height and seat inclination

The higher the rear wheel is attached to the frame, the more the seat inclines downward. This positions the user deeper and more firmly into the seat. However, rear wheels that are attached high at the frame also make the wheelchair more prone to tilt backwards. A careful and synchronized height adjustment of both the rear wheels and the casters will allow to adapt the seat height to the user's individual requirements.



INFORMATION!

Please note: When the rear wheel position is changed, the angle of the caster axle in relation to the ground also changes. Ensure that this angle is always approx. 90° wide (see "Caster wheels"). The wheel lock must be re-adjusted as well (see "Wheel lock") .



INFORMATION!

The Start **M1 Intro**, **M2 Effect**, **M3 Hemi** and **M6 Junior** offer the possibility to change the vertical position of the rear wheel by shifting the rear wheel adapter along the frame. Loosen the two screw connections A (Fig. 24) and remove the screws. Shift the adapter to the desired position and firmly retighten the screws.



INFORMATION!

Make sure to firmly retighten all screws and nuts after making adjustments. The proper torque for the screw connection of the rear wheel adapter is 8 Nm. The proper torque for the screw connection of the fitting is 50 Nm.

For **Start M4 XXL** and **M5 Comfort**: Loosen the nut A (Fig. 25) of the quick-release axle housing on the inside of the frame and remount the axle housing at the desired position. The proper torque is 50 Nm. The distance between rear wheel and side panel can be continuously adjusted by adjusting the counter nut on the outer side of the frame.

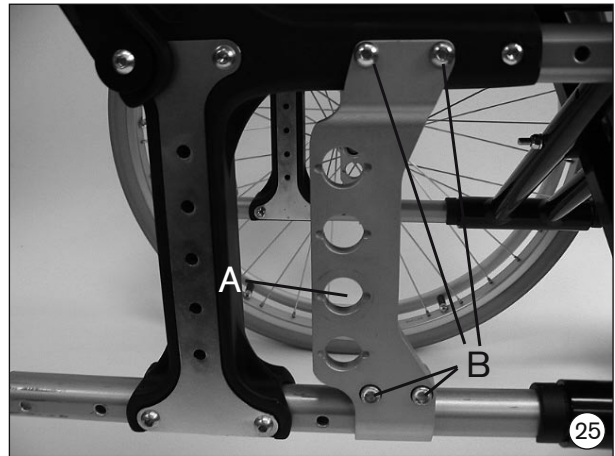
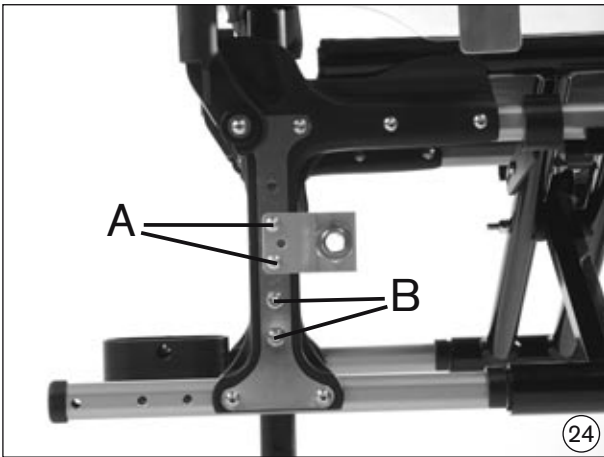

6.2 Changing the wheelbase

Shifting the rear wheel backwards lengthens the wheelbase and thus provides for greater stability of the wheelchair. Shifting the rear wheel forwards (only for advanced wheelchair drivers!) relieves the load on the casters. This increases the maneuverability of the wheelchair. The caster wheels can then also be lifted more easily to clear obstacles such as curbs or steps.



DANGER!

Please note: If the rear wheels are in a more forward position and the user's body is not appropriately positioned, the user may tip backward - even on level ground!



DANGER!

For untrained wheelchair users and when there are extreme adjustments to the rear wheel, an anti-tipper is strongly recommended!



DANGER!

For transfemoral amputees it is essential to shift the rear wheels backwards!



INFORMATION!

For **Start M1 Intro, M2 Effect, M3 Hemi and M6 Junior**: Loosen the screws A of the rear wheel adapter (Fig. 24) at the frame and mount the rear wheel adapter (with sides reversed) in the desired position. The distance between rear wheel and side panel can be continuously adjusted by adjusting the counter nut on the outer side of the frame.



INFORMATION!

Make sure to firmly retighten all screws and nuts after making adjustments. The proper torque of the screw connection of the rear wheel adapter is 8 Nm.



INFORMATION!

For **Start M4 XXL and M5 Comfort**: Loosen and remove the 4 screw connections B (Fig. 25) which connect the rear wheel adapter to the frame. The adapter can then be shifted to the desired position on the frame tube and the plastic adapter.

When changing the adjustments originally made in the factory, two other component groups of the wheelchair must be readjusted, refer to sections 6.3 and 6.4.

6.3 Caster wheels

Adjusting the caster wheel journal angle (Fig. 26)

After the rear wheels have been mounted in the appropriate position, the caster wheel journal angle must be readjusted.

The threaded axle should be as horizontal as possible in relation to the ground to ensure optimal driving behavior of the wheelchair. The caster adapter allows for continuous angle adjustment.



INFORMATION!

Loosen the two screws A between caster adapter and frame (Fig. 26). Now you can move the caster adapter along the frame tube. The level (included in delivery) will help you position the threaded axle as vertically to the ground as possible.



INFORMATION!

Make sure to firmly retighten all oval head screws. The proper torque is 8 Nm (Fig. 26).

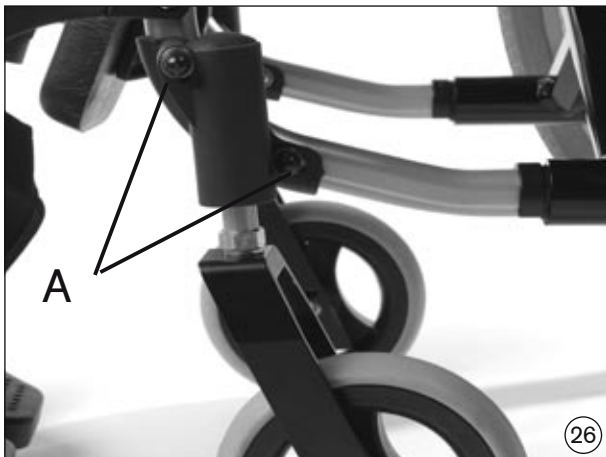

6.4 Wheel lock

To change the position of the rear wheels, first loosen the attachment screws of the clamping adapters of the wheel lock and push the wheel lock forward. Then reposition the rear wheels. The wheel lock should then be remounted such that the distance between the tires and wheel lock bolts is max. 4 mm when the wheel lock is not activated (subject to technical changes) (Fig. 27). Check the tire air pressure and the effectiveness of the locking devices regularly. The proper air pressure is indicated on the side wall of the tire. It should be at least 3.5 bar (350 kPa). To ensure sufficient braking effect, use only original rear wheels with an approved radial excursion of maximally ± 1 mm.



INFORMATION!

Make sure to firmly retighten all screws and nuts after making adjustments!



INFORMATION!

Tighten the wheel lock attachment with a torque of 10 Nm.



6.5 Adjusting the brake force for rear wheel with drum brake

The brake force is adjusted at the adjustment screw to achieve optimal braking effect. The brake force is increased by turning the screw counter-clockwise and decreased by turning the screw clockwise.



INFORMATION!

Turn the adjustment screw counter-clockwise until frictional noise occurs at the turning wheel. Then tighten the adjustment screw until the frictional noise disappears. The wheel should run freely.

After finishing the adjustment, fasten the adjustment screw by tightening the counter nut.



INFORMATION!

Ensure that the brake force of both rear wheels is adjusted equally. Also make sure that the drum brake engages with sufficient force only when the manual brake lever is set to the second ratchet position.

6.6 Adjusting the angle of the footplate (Fig. 28)



INFORMATION!

Prior to adjusting the footplate angle, loosen the screw connections A as indicated in the figure. Then set the footplate to the desired angles and tighten the loosened screw connections with a torque of 6 Nm.

6.7 Adjusting the height of the footrest (Fig. 29)



INFORMATION!

By loosening the set screw, the footplate can be adapted to your lower leg length and to the thickness of your seat cushion.



INFORMATION!

Make sure when adjusting the footrest height, that the footrest bar is slid into the swivel segment at least 40 mm. A marking on the footrest bar indicates how far the bar should be slid in.



INFORMATION!

After having made adjustments, retighten the set screw to a torque of 6 Nm.



6.8. Adjusting the angle of the elevating footrest (Fig. 30)

Turn the release lever until it hits the stop. While propping up the footrest bar, set the desired angle. Then carefully let the release lever turn back. At the next free position, the footrest will snap into place.



6.9 Adjusting the height of the armrest for desk side panel

The armrest can be set to three different heights. In the standard assembly, the armrest is mounted firmly onto the tube bend.



INFORMATION!

To increase the armrest height, remove the two cap screws completely from the tube bend. Then place the two distance pieces above the tube bend between armrest and side panel tube to adjust a further height.



INFORMATION!

Make sure to firmly retighten all screws and nuts after making adjustments.

6.10 Adjusting the seat depth (Fig. 31)

Undo the hook-and-loop attachment between back padding and seat upholstery.

Loosen the screw connections A that connect the rear wheel adapter to the open frame tube. Remove the screws. The rear wheel adapter can then be shifted along the frame tube. Three different seat depth adjustments, in 3 cm increments, are possible.



INFORMATION!

Make sure to firmly retighten all screws and nuts after making adjustments (6 Nm). Fasten the hook-and-loop attachment again between the back padding and the seat upholstery.

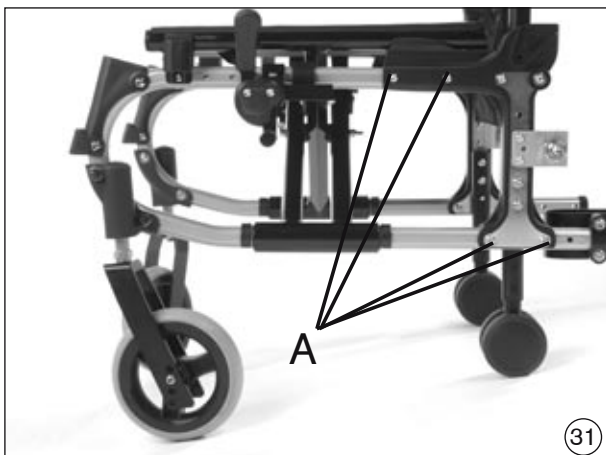

6.11 Adjusting the back height (Fig. 32)

The back tube which is integrated into the posterior frame allows for the adjustment of the back height in increments of 2.5 cm.



INFORMATION!

Remove the screws A and B from the rear wheel adapter.
Set the desired back height.



INFORMATION!

Make sure to firmly retighten all screws and nuts after making adjustments (8 Nm).

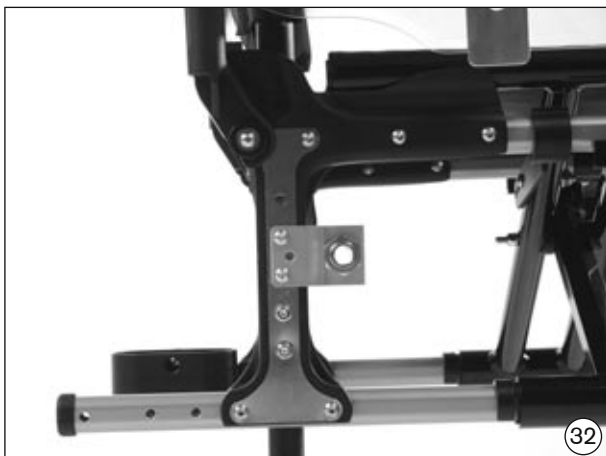

6.12 Seat upholstery (no figure)

Should your seat upholstery become stretched out after longer use, contact your dealer to have it replaced with a new seat upholstery.

6.13 Adapting the back upholstery (Fig. 33)

If you have selected the option “adaptable back upholstery”, you can adjust the back upholstery in segments according to your needs.



INFORMATION!

To do this, remove the back upholstery padding and undo the hook-and-loop fasteners of the straps. Reposition the straps as desired, attach them again with the hook-and-loop fasteners and cover with the padding.



DANGER!

Using your Otto Bock product as a seat for transportation in motor vehicles for the disabled

We recommend that, wherever and whenever possible, users of a wheelchair, mobility base with seating shell or buggy transfer to the seats installed in the motor vehicle for the disabled and use the corresponding vehicle restraint systems, as this is the only way to ensure optimal protection of the passengers in case of an accident.

Your Otto Bock product M1, M2, M3, M5 and M6 is permissible for transporting passengers in motor vehicles for the disabled when using Otto Bock safety components as well as appropriate restraint systems.

For more information, please refer to our instructions for use manual "Using your Wheelchair/ Mobility Base with Seating Shell or Buggy as a Seat for Transportation in Motor Vehicles for the Disabled", order no. 646D158.

6.14 Setting rear wheel tracking (M5) (Fig. 34, 35)

The correction plate, which is angled twice, is to be mounted to the adapter with the rear wheel fitting and the camber washers. To correct wheel tracking, put the level on the straight edge of the correction plate and turn the plate until the camber washers are level. Next, fix the plate with the 6 mm oval head screw. Finally retighten the M18x1 nuts.



INFORMATION!

Make sure to firmly retighten all screws and nuts after making adjustments. Observe the values indicated in section 6.1.

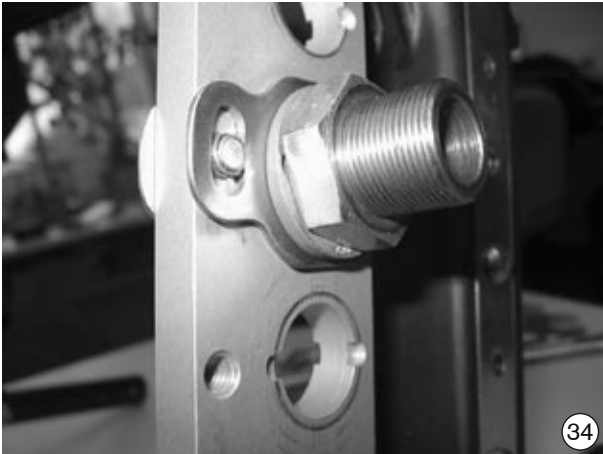

7 Maintenance, Cleaning and Care

Your Start wheelchair has been provided with the CE marking. The manufacturer herewith guarantees that this medical product as a whole conforms to the requirements of the European Directive for Medical Products 93/42/EEC.

The proper function of the wheelchair, especially of the brakes, should be checked before every use. Safety nuts should be used only once. If they have been loosened several times, they must be replaced.

In the case of defects, contact your authorized dealer immediately to eliminate them. This applies in particular when the driving behavior changes or the wheelchair becomes unstable.

We also recommend that you have the wheelchair serviced every 12 months by your Otto Bock authorized dealer.

The following table lists functions which the user must check at the indicated intervals.

Check	before each use	monthly	quarterly
Function test of the wheel locks/brakes	X		
Sagging of the seat or back upholstery		X	
Setting of the caster journal bearing		X	
Sight-check of wearing parts (e.g. tires, bearings)		X	
Dirt on bearings		X	
Push rings for damages		X	
Air pressure (see indication on tire)		X	
Folding mechanism for wear and tear		X	
Spoke tension of the rear wheels			X
Screw connections			X

To ensure smooth operation at all times, some parts of the wheelchair can be maintained by users with minimal technical skills:

- Hair and dirt frequently collect between the caster forks and the casters; over time, they make the casters stiff to operate. Remove the casters and thoroughly clean the forks and casters using a mild household cleaner.
- The rear wheels and casters may have been configured as a quick-release axle system. To keep this system operational, ensure that no dirt adheres to the quick-release axle or quick-release axle housing. Periodically lubricate the quick-release axle very lightly with resin-free sewing machine oil.
- If your wheelchair gets wet, it is recommended to dry it off as soon as possible.
- Do not use your wheelchair in salt water and, if possible, prevent sand or other dirt particles from coming into contact with the wheel bearings.

- Screw connections should be periodically checked for tightness, especially during the initial period of use or after making adjustments to the wheelchair. If a screw connection comes loose repeatedly, please consult your specialist dealer.

Cleaning and Disinfection

Clean the cushions and upholstery with warm water and a mild detergent. Remove spots with a sponge or a soft brush. Rinse with clear water and let the components dry.



Note!

Do not use any aggressive cleaners, solvents, or hard brushes etc.



Note!

Do not immerse in water. Components are not machine washable.

Water-based disinfectants (e.g. Sagrotan original concentrate) should be used for disinfection. The manufacturer's instructions for use must be observed.



Note!

Before disinfecting, the pads and handles must be cleaned.

Plastic parts, frame parts, and the chassis and wheels can be cleaned with a mild cleaner and a damp cloth. Dry thoroughly afterwards.

8 Changing Tires

Changing flat tires requires only the necessary tools and minimal technical skills. Users may change tires themselves if they wish. We recommend carrying an emergency repair set and an air pump at all times (if using pneumatic tires). Alternatively, users can keep a spray can of hardening foam (available at bicycle shops) to fill a tire in case of punctures.

- In case of a flat tire, carefully remove the tire from the rim using the appropriate tools.
- Take care not to damage the rim or the inner tube.
- Repair the inner tube according to the directions in the repair kit, or, replace the damaged inner tube with a new one.
- Before re-mounting the tire, inspect the inner rim surface and the inside of the tire for any object that may have caused the puncture.
- Be sure that the rim bands are not damaged. They protect the tube from being damaged by the ends of the spokes.

Mounting (Fig. 36)

- Place the protective rim band over the valve. Then push the valve through the rim. Screw on the valve nut, if there is one. The rim band can then be easily applied.
- Ensure that all spoke ends are covered.

Tires (Fig. 37)

- Beginning behind the valve, place the lower side of the tire over the edge of the wheel rim. Pump the tube with a small amount of air until it is round. Then insert it in the tire.
- Check the inner tube for folds. If folds are present, release some air. The rest of the tire can then be mounted by, starting with the section of tire opposite the valve, gently pressing the tire toward the valve.



Inflating

- Check around the tire on both sides to ensure that the tube is not clamped between the edge of the tire and the rim.

Push the valve back slightly and then pull it out again such that the tire is well-seated in the valve area.

- Inflate the tire until it can still be pressed easily with your thumb. If the control line on both sides of the tire is equally distanced to the rim, the tire sits centrally. If the tire does not sit centrally, let out some air and realign the tire. Then inflate the tire to the pressure indicated on the side wall and tighten the dust cap.

9 Technical Data

Overall length (in cm)

	Rear wheel size					
	20x1 3/8"		22x1 3/8"		24x1 3/8"	
Module	Rear axle position	Front axle position	Rear axle position	Front axle position	Rear axle position	Front axle position
M1	-	-	100	90	103.5	94
M2, M3	-	-	100.5	90	104	94
M4	-	-	100.5	87.5	104	91
M5	-	-	97.5	81.5	101	85
M6	89.5	79	92	81.5	95.5	85

Overall width (in cm)¹⁾

Seat width	Standard rear wheel max.	Rear wheel with drum brake max.
28	47	49.5
30.5	49.5	52
33	52	54.5
35.5	54.5	57
38	57	59.5
40.5	59.5	62
43	62	64.5
45.5	64.5	67
48	67	69.5
50.5	69.5	72
53	72	74.5
55.5	74.5	77
58	77	79.5

¹⁾ Applicable to push ring attachment, narrow (for push ring attachment, wide: +2 cm) and a 0° camber of the rear wheels.

Start M1, M2, M3, M4, M5, M6
Anterior seat height (in cm)
without wider foot space

Caster fork, short		
Position		Setting range*
Caster diameter	5"	40-44
	5.5"	42-45
	6"	42-45
	7"	45-47
	8"	47-48
Caster fork, long		
Position		Setting range*
Caster diameter	5"	42-46
	5.5"	42-47
	6"	43-47
	7"	44-49
	8"	46-50

* Indications without seat cushion and with a seat inclination of 0°

Anterior seat height-posterior seat height ≤ 3.5 cm
Casters in dependency of the anterior seat height
Caster fork in dependency of the anterior seat height and casters
Rear wheel size in dependency of the posterior seat height

Start M1, M2, M6
Posterior seat height (in cm)

Posterior seat height		Setting range
Rear wheel size	20"	35-45
	22"	37-47
	24"	43-50

Start M4, M5
Posterior seat height (in cm)

Free mounting positions	Rear wheel size	
	22"	24"
1	38	41
2	41	44
3	44	47
4	47	50

Start M3
Anterior seat height (in cm)
wider foot space

Caster fork, short		
Position		Setting range*
Caster diameter	5"	36-41
	5.5"	39-42
	6"	39-42
	7"	42-44
	8"	44-45
Caster fork, long		
Position		Setting range*
Caster diameter	5"	40-44
	5.5"	41-45
	6"	42-46
	7"	43-47
	8"	44-48

* Indications without seat cushion and with a seat inclination of 0°

With the option "without wider foot space", the anterior seat height values of the M5 apply.

Anterior seat height-posterior seat height ≤ 3.5 cm
Casters in dependency of the anterior seat height
Caster fork in dependency of the anterior seat height and casters
Rear wheel size in dependency of the posterior seat height

Rear wheel adapter

M1, M2, M3, M6

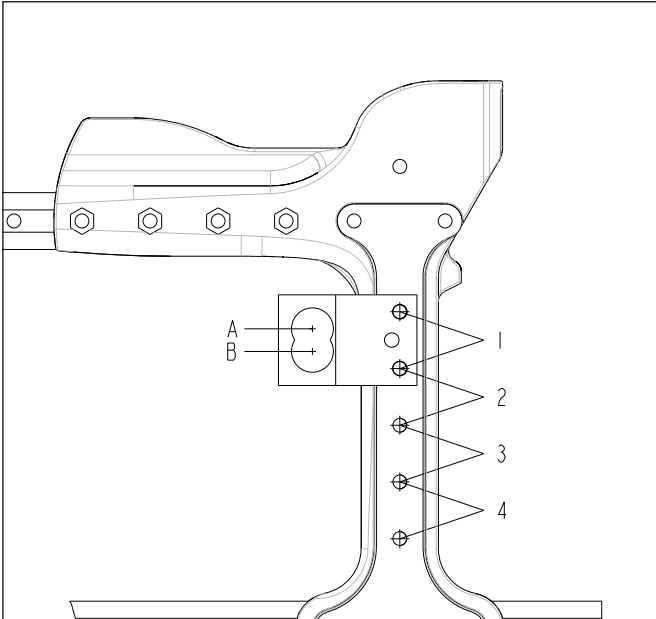

M4, M5

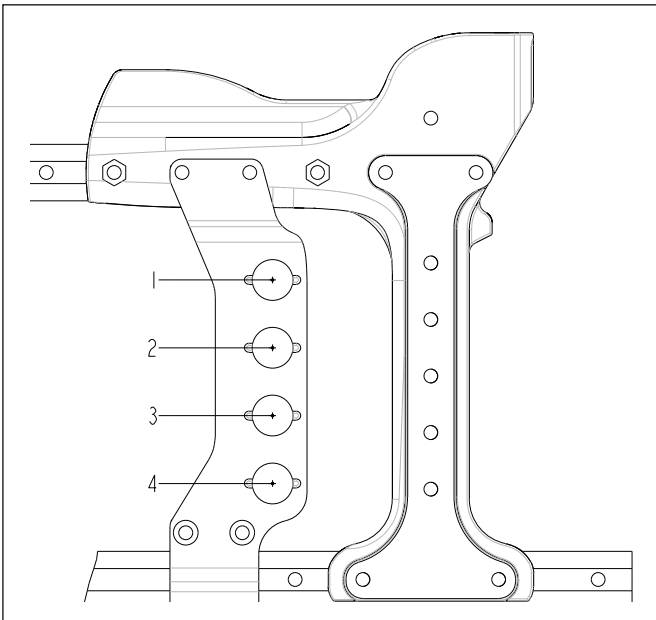

10 Information on Re-use

The Start Series lightweight wheelchairs are suitable for re-use.

Similar to second-hand machines or cars, products that are being re-used are subject to increased strain. Features and functions must not change in a way that could endanger patients or other persons within the product's life cycle.

Based on market observations and the current state of technology, the manufacturer has calculated that the Start Series lightweight wheelchair can be used for a period of 4 years, provided that it is used properly and that the service and maintenance instructions are observed. Periods during which the wheelchair is stored at the dealer or with the third party payer are not included in this period. It should be clearly pointed out, however, that Start Series lightweight wheelchair is a reliable product far beyond this defined period of time, provided that it is cared for and maintained appropriately

In cases of re-use, the corresponding product must first be thoroughly cleaned and disinfected. Afterwards, the condition of the product must be examined by an authorized dealer to check for wear and tear as well as any damage.

Any worn and damaged components as well as components which do not fit or are unsuitable for the user must be replaced.

The service manual includes a service schedule, detailed information, and a list of the required tools.

Ihr Fachhändler/Your specialist dealer:

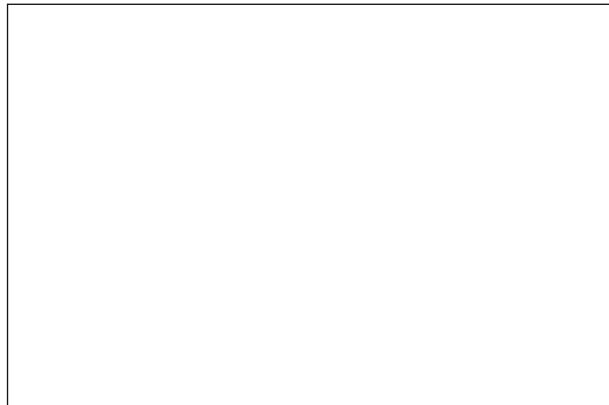

Hersteller/Manufacturer:

Otto Bock HealthCare GmbH

Max-Näder-Straße 15 · 37115 Duderstadt/Germany

National: Telefon (0 55 27) 848 1461/1462/1463 · Fax (0 55 27) 848 14 60

International: Phone +49-5527-848-1304/1562/1590/1594/3663 · Fax +49-5527-848-1676

e-mail: reha@ottobock.de · Internet: <http://www.ottobock.com>

Versandanschrift für Rücksendungen/Address for Returns

Otto Bock HealthCare GmbH

Lindenstraße 13 · 07426 Königsee/Germany



Otto Bock HealthCare GmbH has been certified by the German Society for the Certification of Quality Assurance Systems (DQS) in accordance with DIN EN ISO 9001 standard, reg. no. 779 (management system)